

# Hydraulic Motor Assembly



THE LEADING FORCE behind liquids™ since 1857

## FEATURES:

- Rigid coupling eliminates alignment difficulties.
- Reduced weight and length over split bracket assemblies.
- Economical solution for mounting hydraulic motors.
- SAE A and B two bolt flange mount on the 3611-3622.
- SAE B four bolt flange mount on the 3632-3648
- Rugged construction.
- Simple design.
- Easy to maintain.

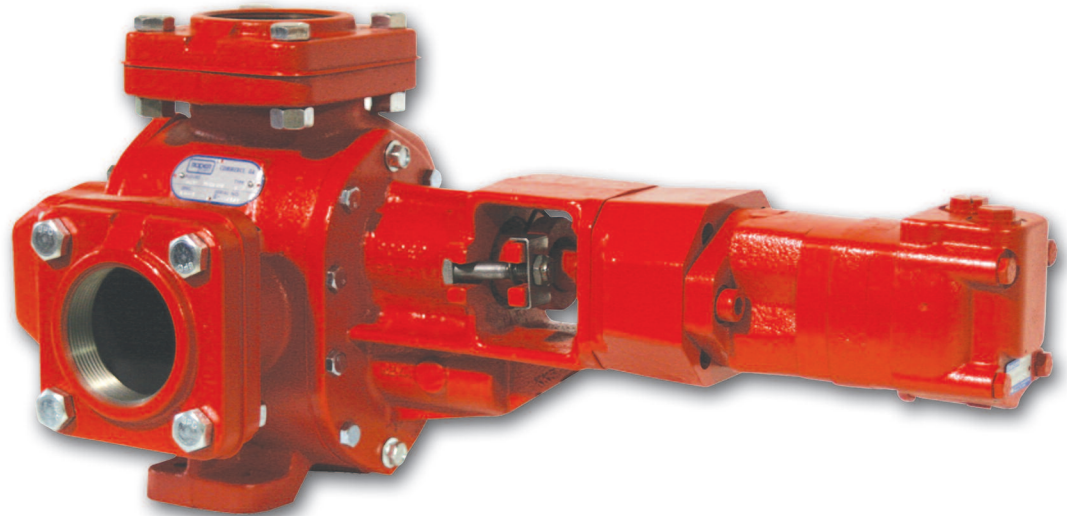

Adapts to existing BH Model Pumps Only  
Go to Hydraulic Motors section of website for proper motor applications.

## BRACKET ASSEMBLY:

Bracket assemblies are available which include the following:

- backplate with bushings
- mounting bracket
- rigid coupling
- hardware

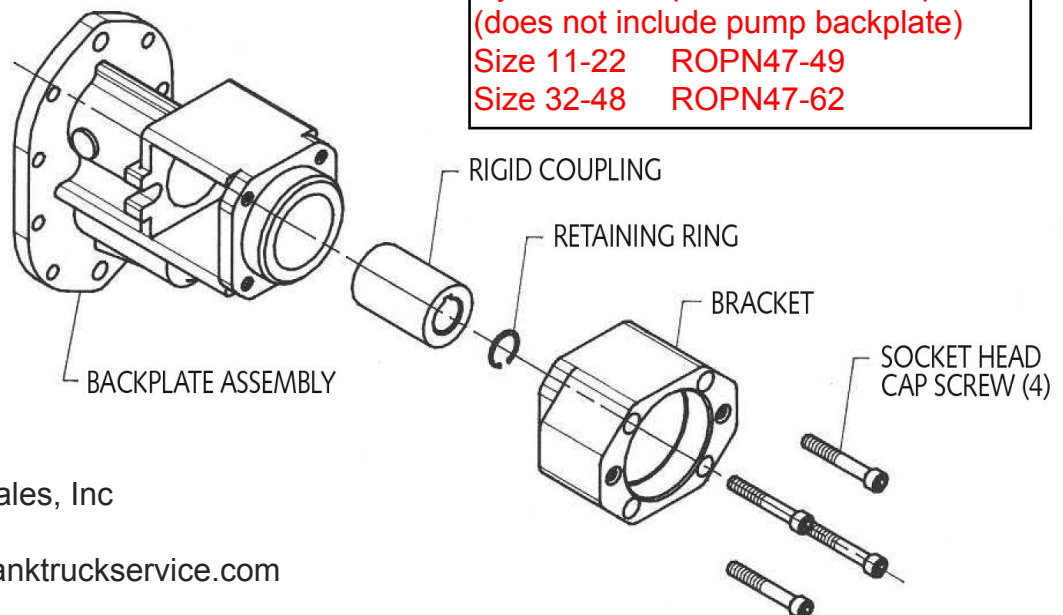

Tank Truck Service & Sales, Inc  
Warren, Michigan  
800-482-2678 www.tanktruckservice.com